

HOW TO MEASURE

getting started

You can easily measure your own countertop and supply a rough drawing. All you need to do is measure the length and width of the cabinets or existing countertop and include backsplashes if any. The location of the sink, dishwasher, cooktop, stove and refrigerator should be supplied in the drawing. Before we begin you will need to obtain these items:

graph paper (provided for you on page 3 of this document), pencil or pen, tape measure, and a ruler.

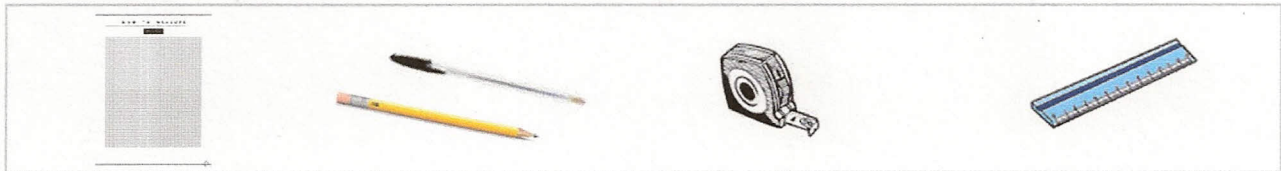

sketching your countertops

Begin by sketching out the basic shape of your kitchen layout on the graph paper provided on page 3. Below is a checklist that should help you with indicating all the appropriate items.

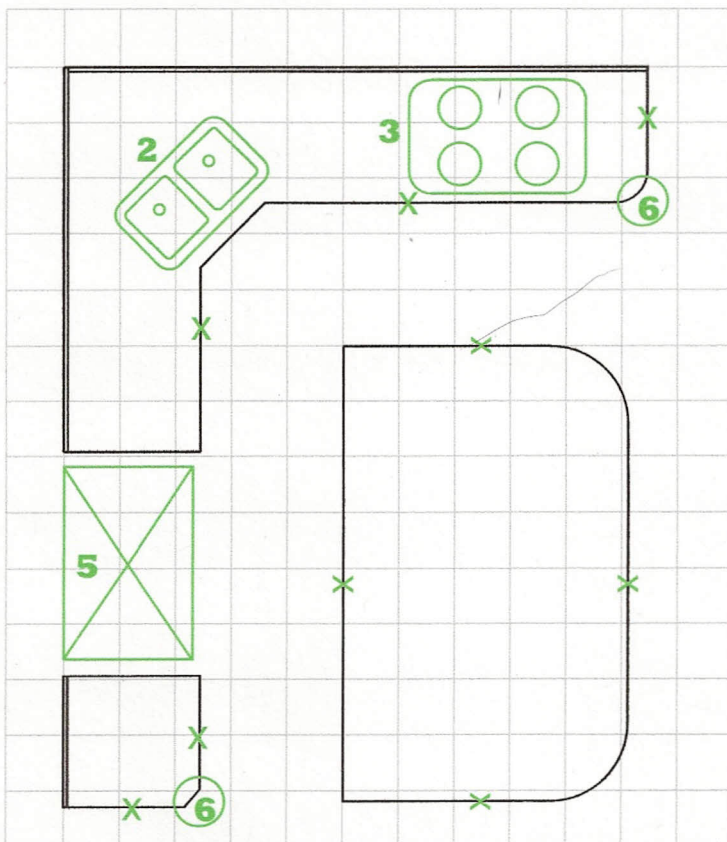

checkoff list

Please complete the checkoff list below to better assist you in the sketching process.

1. Sketch out basic shape of your kitchen layout include all related pieces.....
2. Mark sink location and indicate type of sink (single, double, undermount or drop-in).....
3. Mark stove location and indicate type of stove (cooktop, freestanding or slide-in).....
If it is a slide-in, does it have a small piece of granite behind it? Yes No
4. Mark with (x) all exposed edges that need to be finished.....
5. Indicate any area on the plan that is not granite, like pantry area, refrigerator area, etc....
6. Indicate radius cuts or special edges.....

measuring your countertops

Using the sketch you have completed, indicate the measurement of each piece in inches, be sure to record all measurements accurately. Although your countertop will be measured by a professional prior to fabrication, it is important for you to be as precise as possible in order to obtain an accurate estimate. Please choose one of the steps below either you have existing countertop in place or you have new cabinets to be measured.

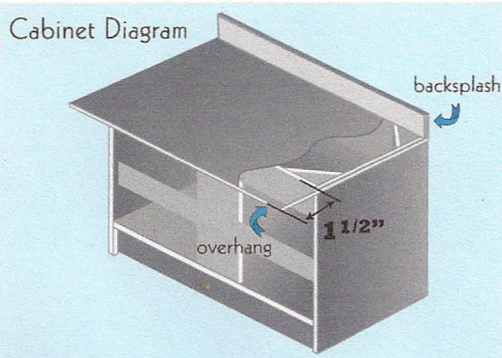
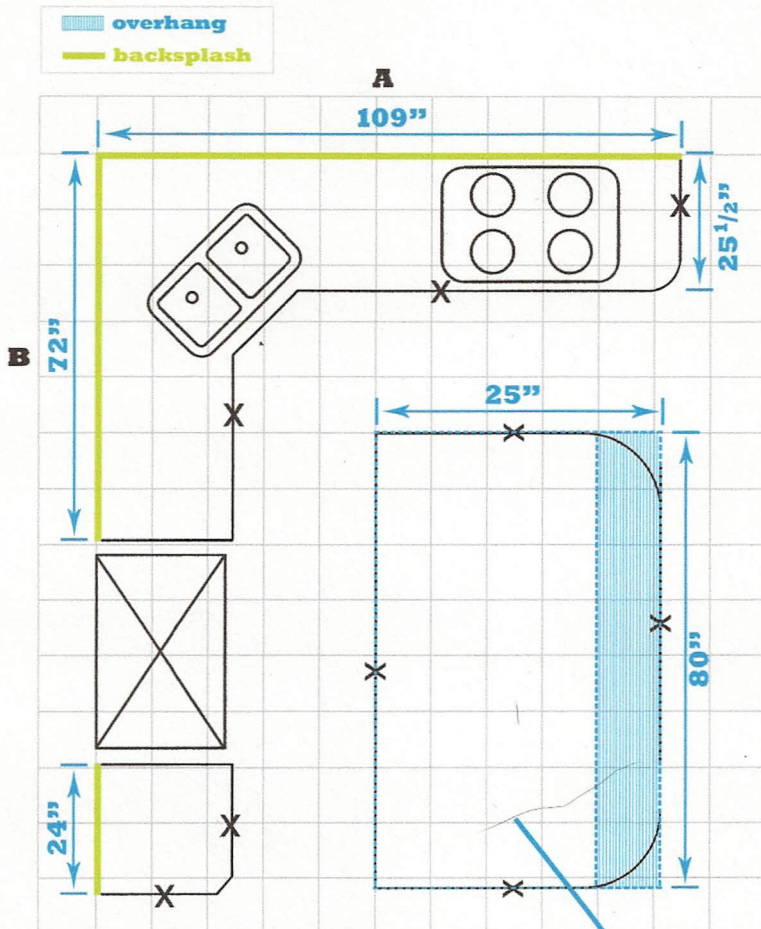

steps in measuring your existing countertop

Please follow steps below in order for your measurements to be as accurate as possible.

Step A - Measuring Length

To measure the length of your existing countertop, measure along the wall from one edge to the opposite edge.

Step B - Measuring Width

To measure the width of your existing countertop, measure from the back wall to the finished front edge.

*If your existing countertop has a backsplash be sure to factor in the thickness. [See Cabinet Diagram]

steps in measuring your new cabinetry

Please follow steps below in order for your measurements to be as accurate as possible.

Step A - Measuring Length

To measure the length for your new countertop, measure along the wall from one edge to the opposite edge.

Step B - Measuring Width

To measure the width for your new countertop, measure from the back wall to the front of the cabinet be sure to add 1 1/2" to the dimension for overhang. [See Cabinet Diagram]

islands

Note: Every rounded piece should be measured as if it were rectangular in shape. Measure the furthest distance possible from the rounded side to the opposite side.

HOW TO MEASURE

graph paper

